

TOLEDO

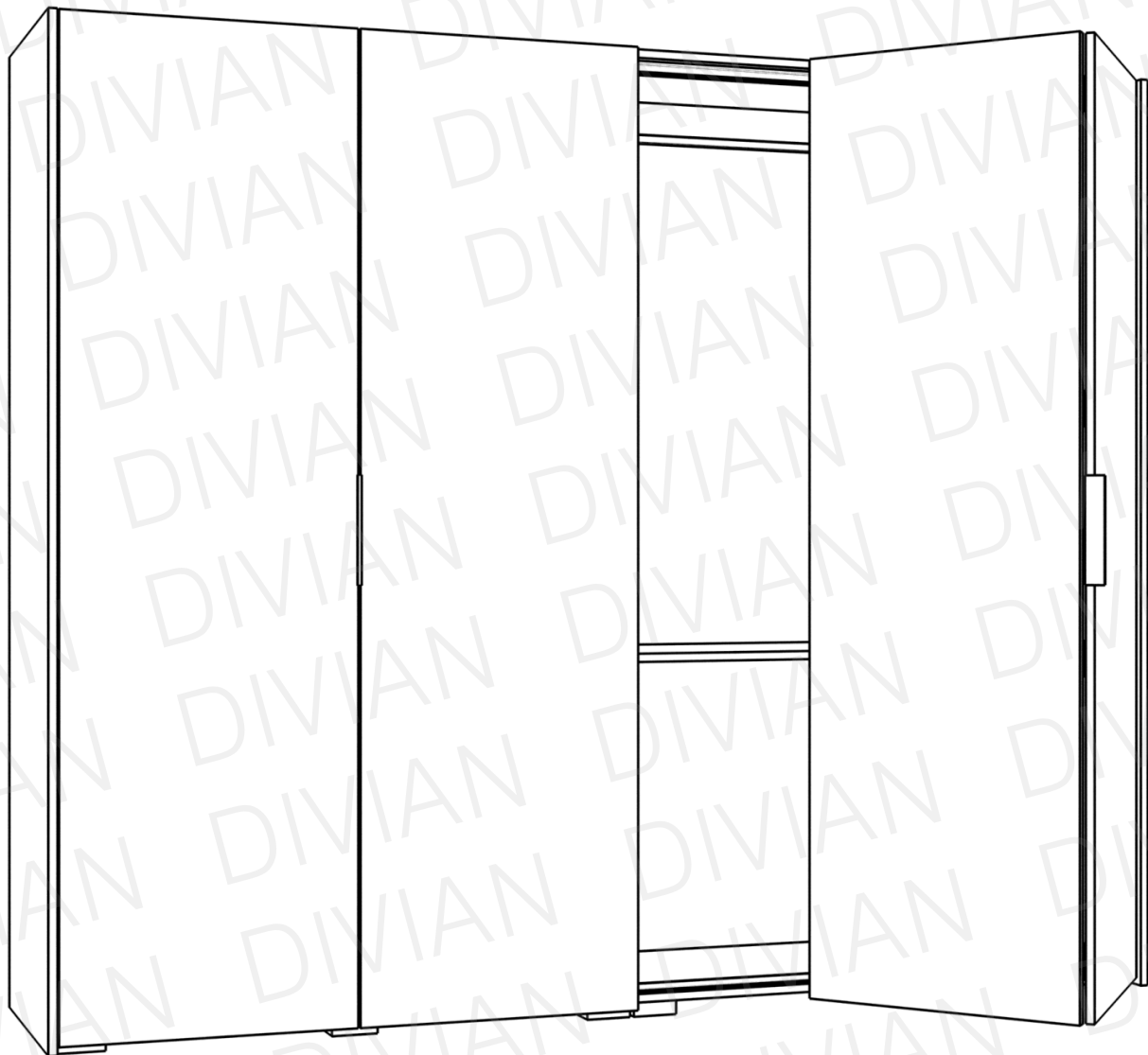

Pontosan kövesse a szerelés lépéseit!

SZERELÉSI ÚTMUTATÓ

Gardrób csomag tartalma:

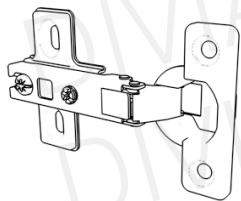

kivetőpánt 8db

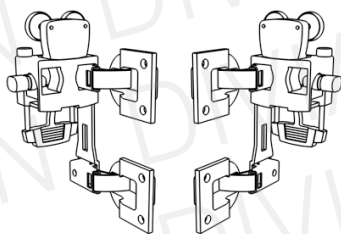

felső görgő 2db
(jobbos, balos)

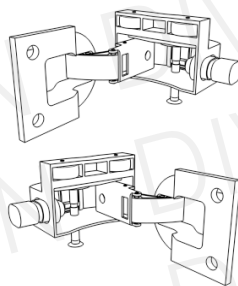

alsó görgő 2db
(jobbos, balos)



középső pánt
alsó elem 8db

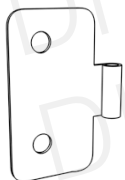

középső pánt
felső elem 8db



bútorösszehúzó
hüvely
M6x30 8db



bútorösszehúzó
csavar
M4x12 8db



bútorösszehúzó
csavar
M4x25 16db

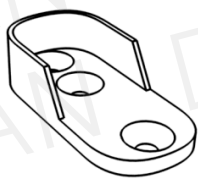

rúdtárcsa 4db



3,5x16 csavar 8db



takarósapka 10db



4x18 csavar 100db

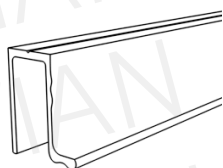

felső sín 1db

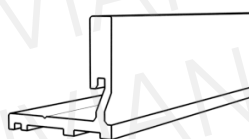

alsó sín 1db

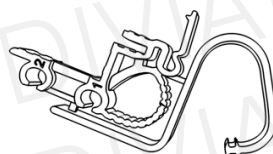

sín sablon 2db



fogó 2db

Szükséges szerszámok:

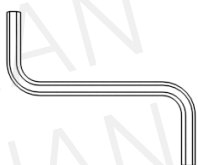

**Ne egyedül végezze
az összeállítást!**

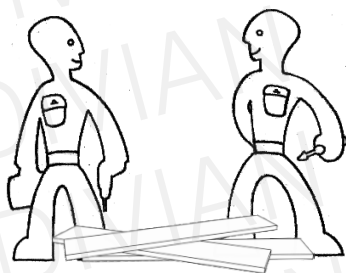

Óvja az elemeket a sérülésektől!

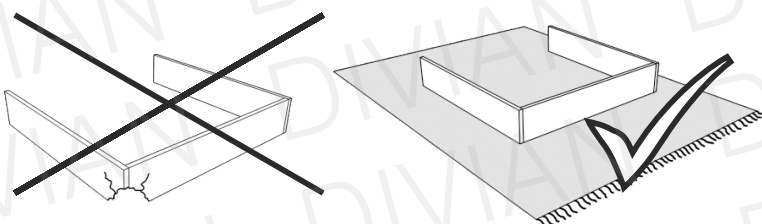

A csomagok több alkatrészt tartalmazhatnak, mint amennyire szüksége van!

1

8x M6x30 8x M4x12

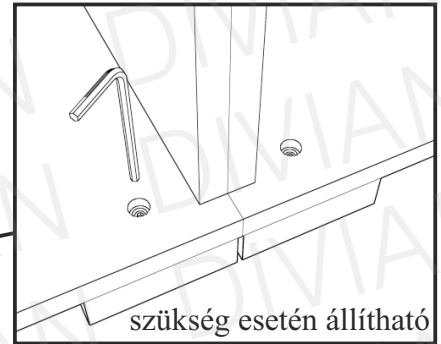
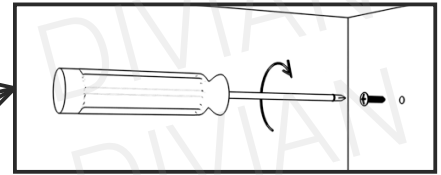
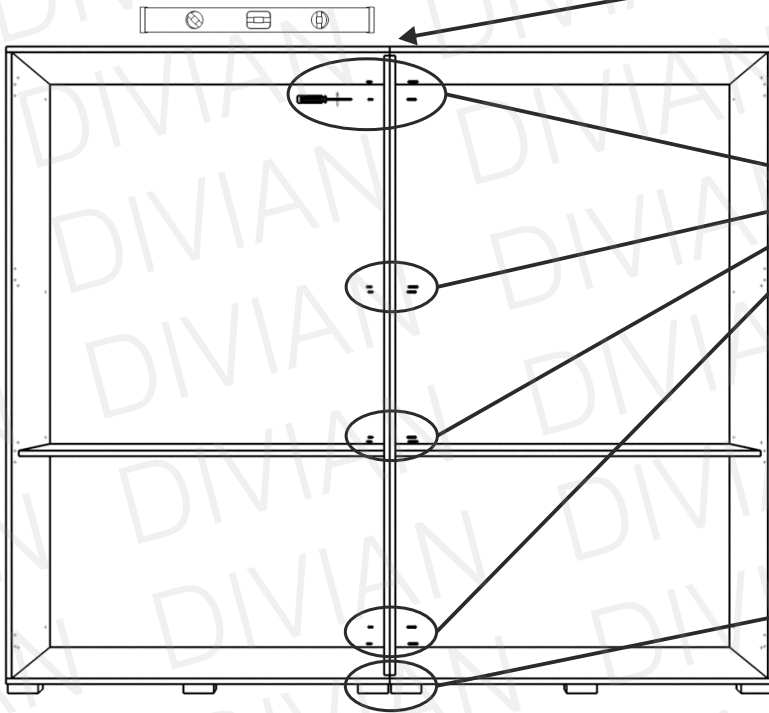
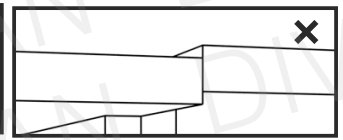
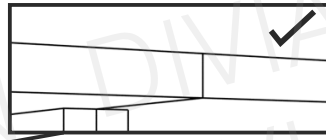
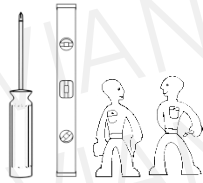

i

A belső mozdítható elrendezést szedjük ki a korpuzokból (fiókkonténer, polcok, mandlirudak), mielőtt összeillesztik az elemeket!

2

16x M4x25

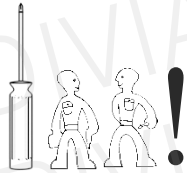

i

Szereljük fel a 2 oldalfalat a bútorösszehúzó csavarok segítségével.

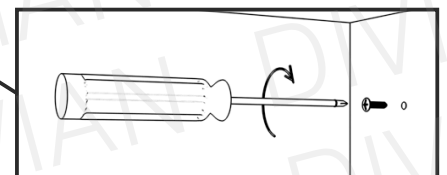
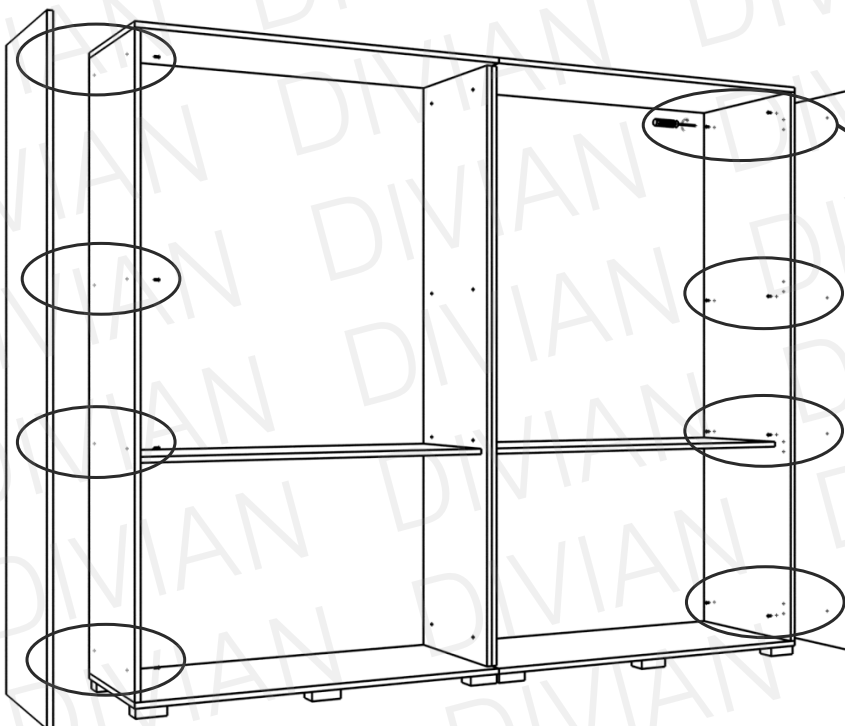

3

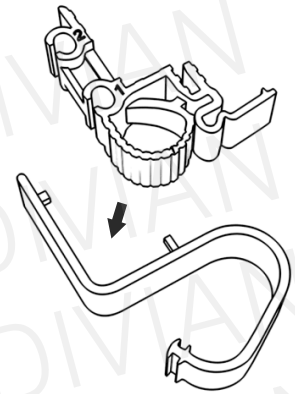
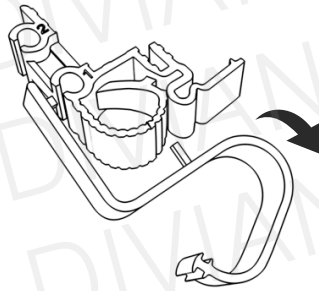
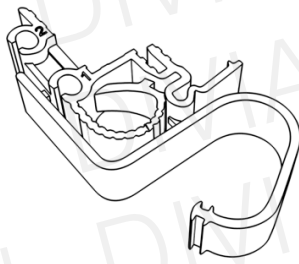
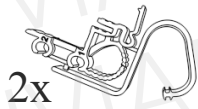
3**i**

Törjék szét a sínek szerelését segítő elemeket!

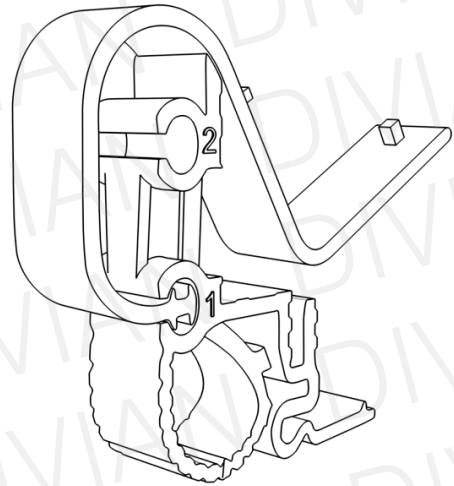
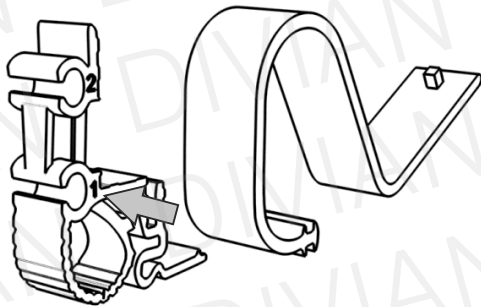
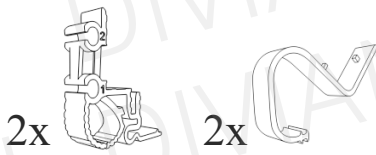
4**i**

Illeszék egymásba a kép alapján a 2-2 elemet. A felső sín szereléséhez az 1-es számmal jelölt pozícióban kapcsolják össze az elemeket.

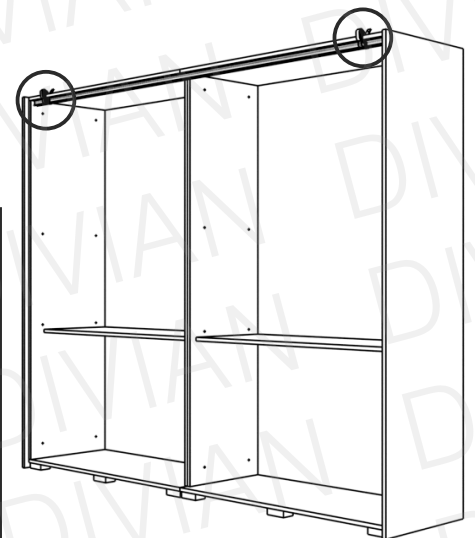
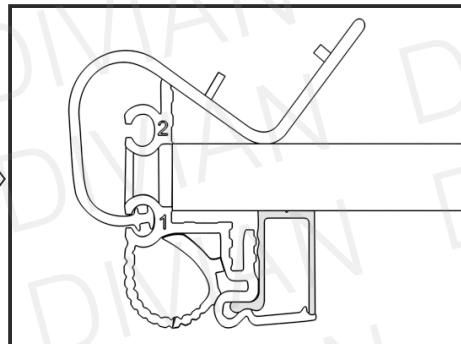
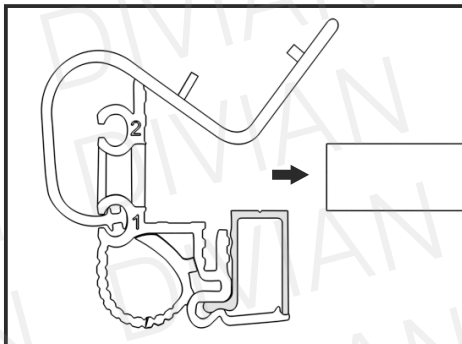
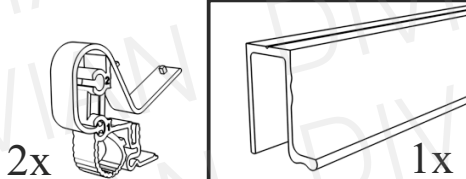
5**i**

Illeszék a felső sínre a segítő elemeket! Majd helyezték a gardrób felső bútorlapjára, ütközésig, szorosan illesztve!

6

10x

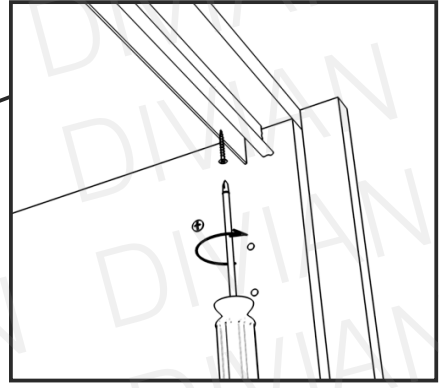
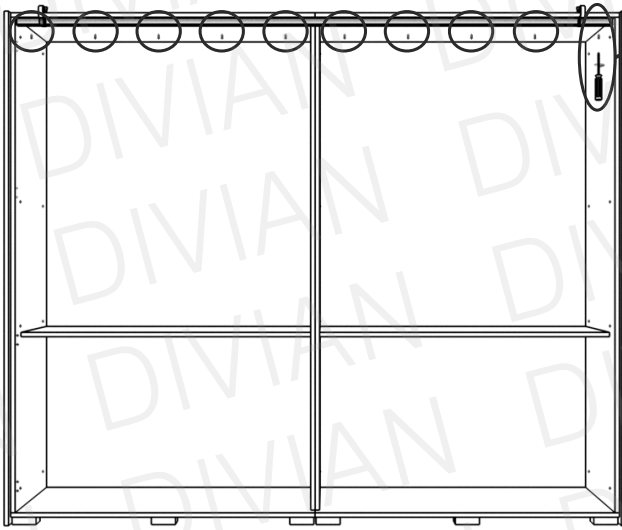
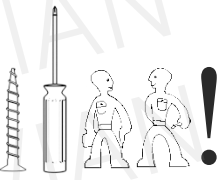

i Ha rögzítették a felső sín a csavarok segítségével, akkor szedjük le a felső sínről a segéd elemeket!

7

2x

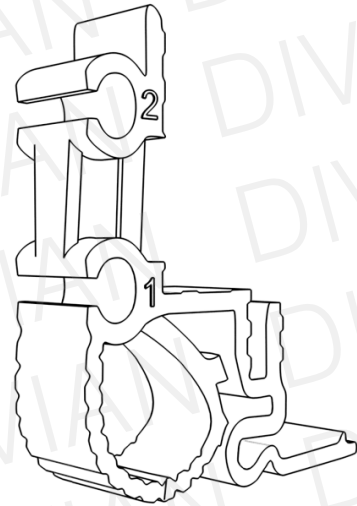
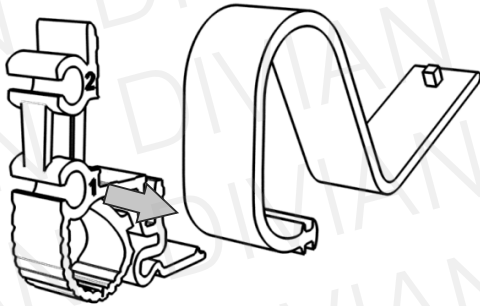
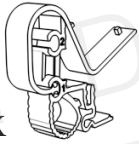

i Szedjük szét az egymásba illesztett segéd elemeket. Az alsó sín szereléséhez a számmal jelölt elemre lesz csak szükség.

8

2x

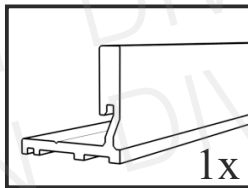
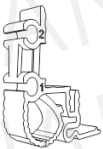

1x

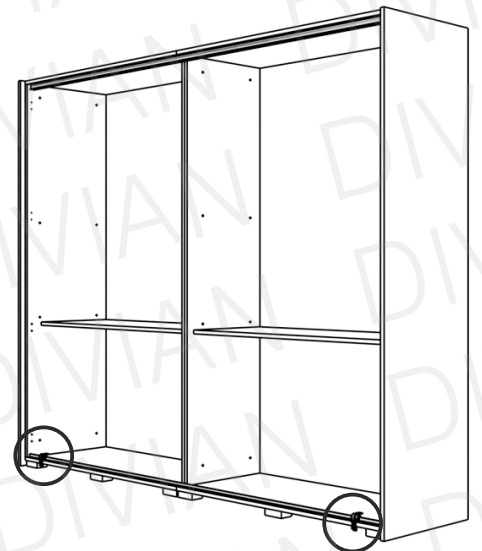
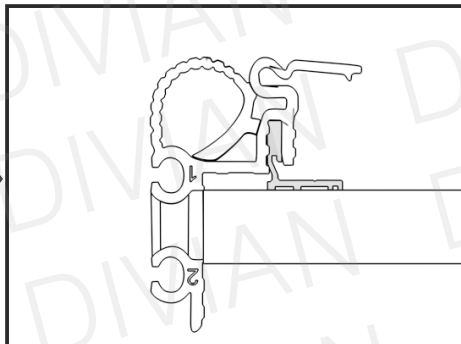
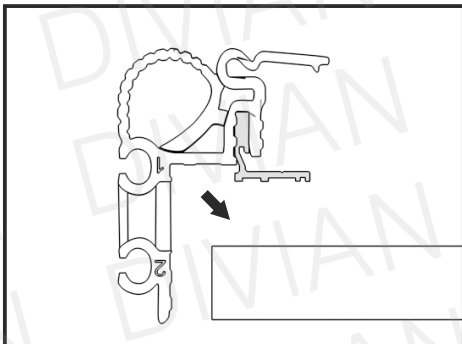

i Illeszék az alsó sínre a segítő elemeket! Majd helyezték a gardrób alsó bútorlapjára, ütközésig, szorosan illesztve!

9

10x

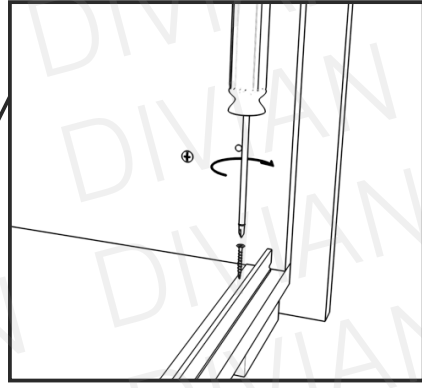
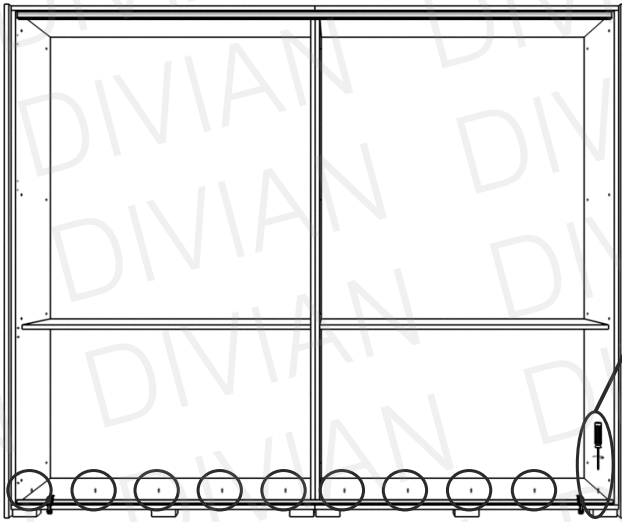
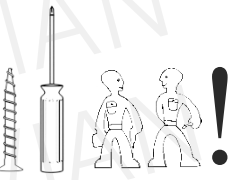

Ha rögzítették az alsó sít a csavarok segítségével, akkor szedjék le az alsó sínről a segéd elemeket!

10



Tervezzék el az ajtó panelek helyzetét!

HÁTULNÉZET:



Jobbos ajtó
külső panel



Jobbos ajtó
belső panel



Balos ajtó
belső panel

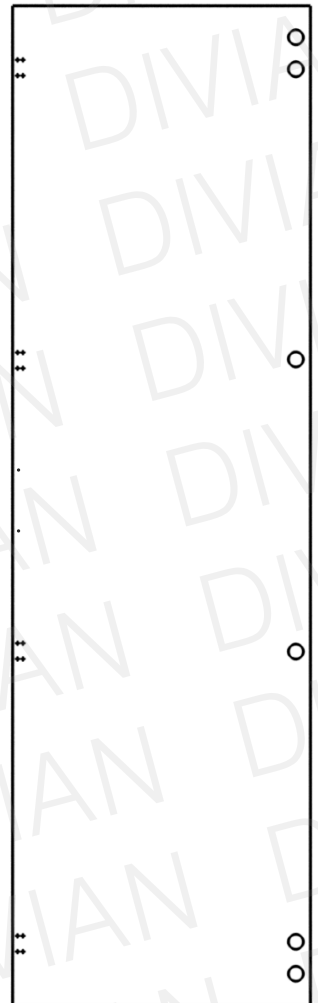

Balos ajtó
külső panel

Balos ajtó, külső panel

11

4x

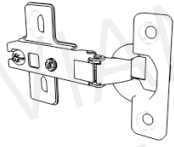

4x



1x



18x



4x18

2x

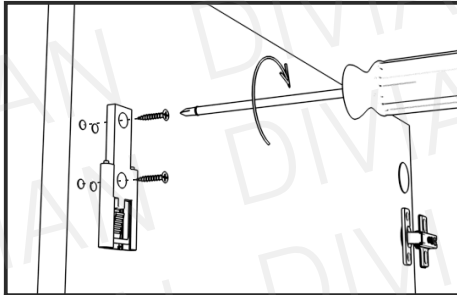

i

A panel széléhez közelebbi, külső 2 furatba csavarja be az alkatrészt!

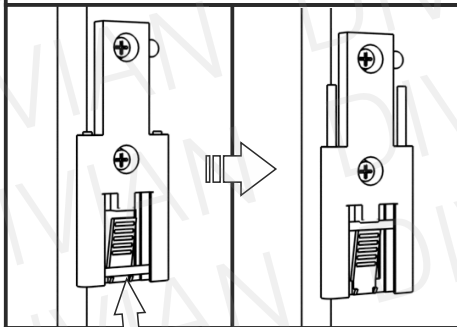

i

Tolja fel az alkatrész U alakú fém részét!

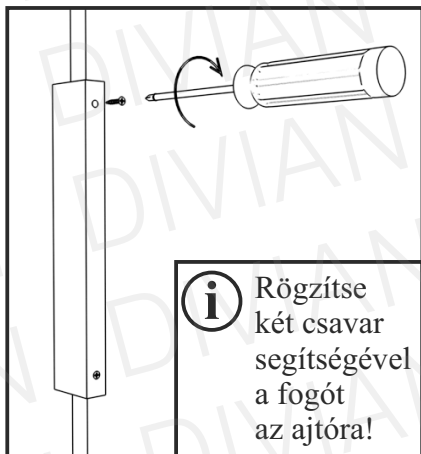

i

Rögzítse két csavar segítségével a fogót az ajtóra!

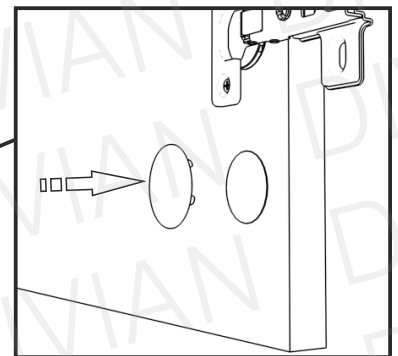
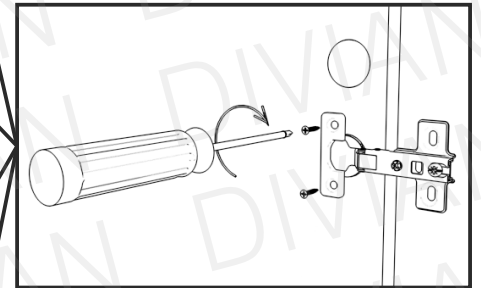
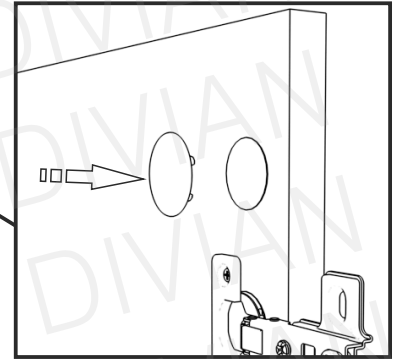

Balos ajtó, belső panel

12

1x

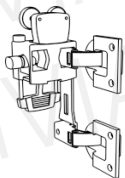

1x

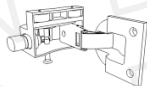

4x



14x



4x18

3x

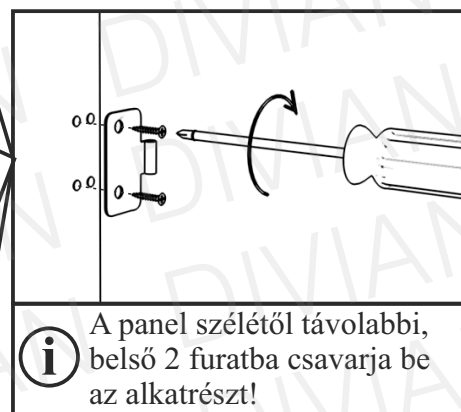
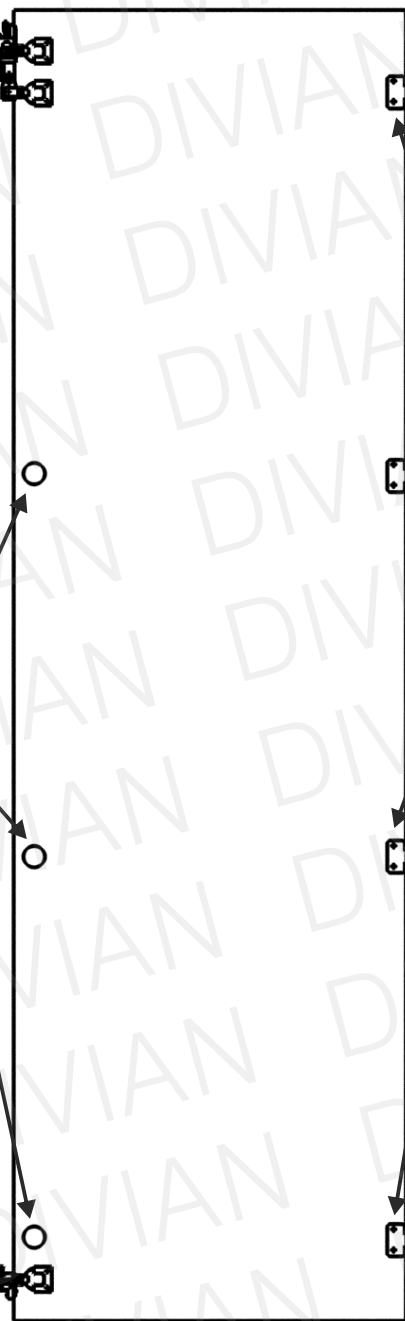
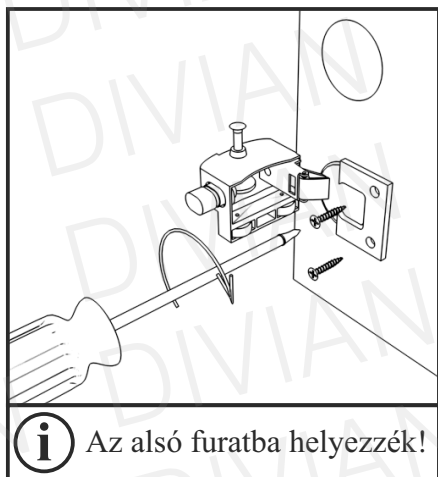
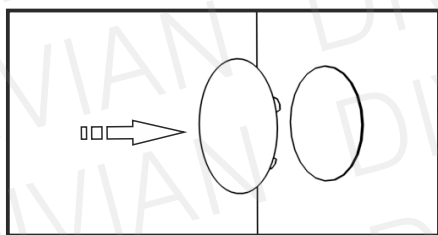
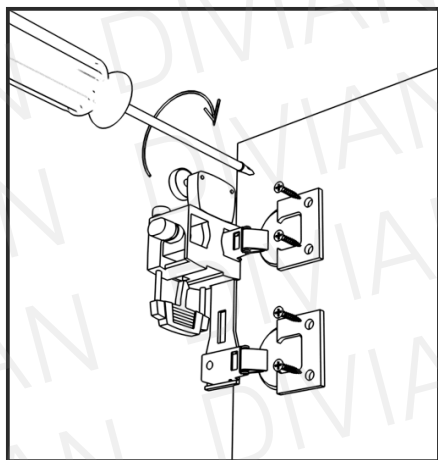

i Az alsó furatba helyezték!

i A panel szélétől távolabbi, belső 2 furatba csavarja be az alkatrészt!

Jobbos ajtó, belső panel

13

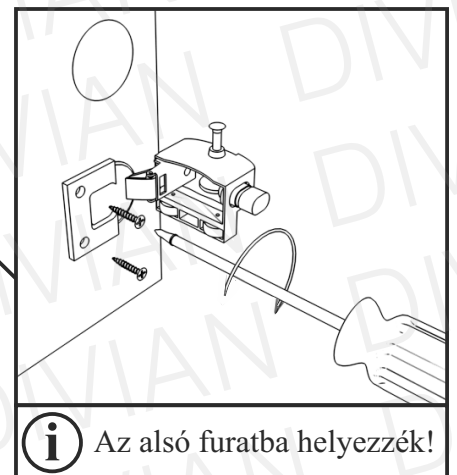
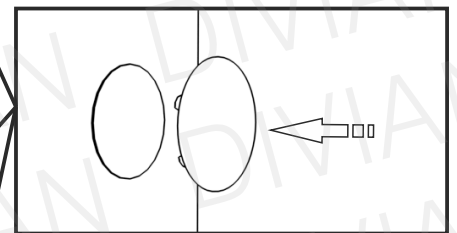
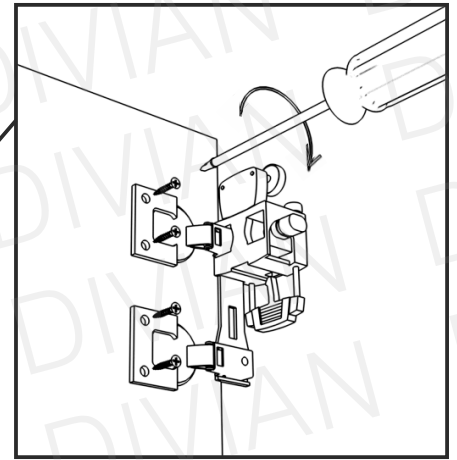
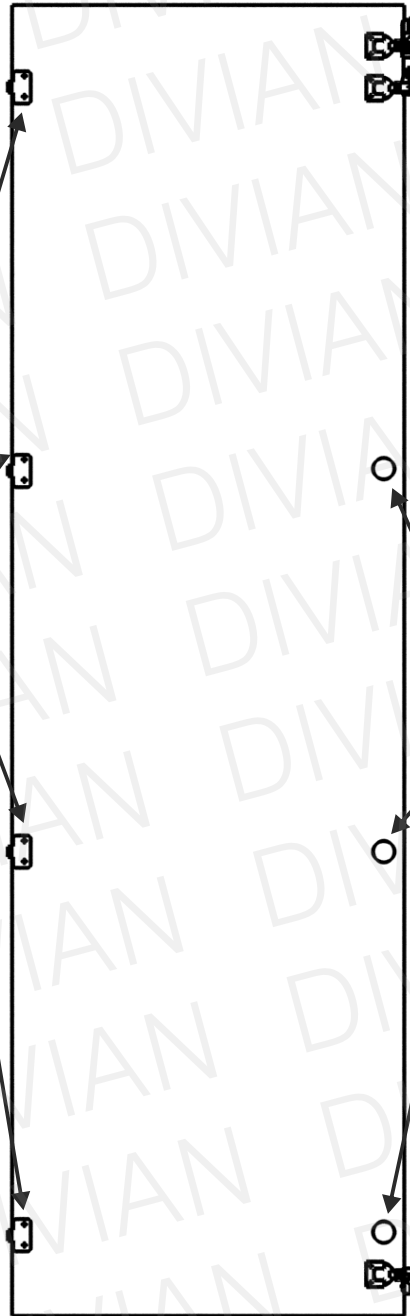
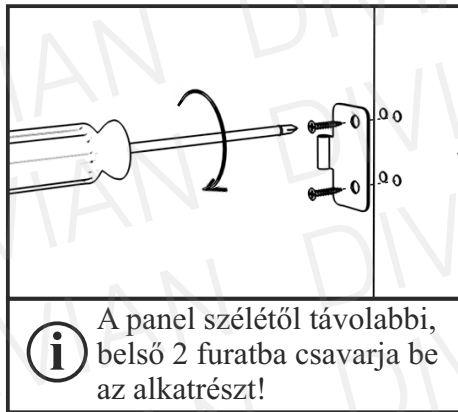
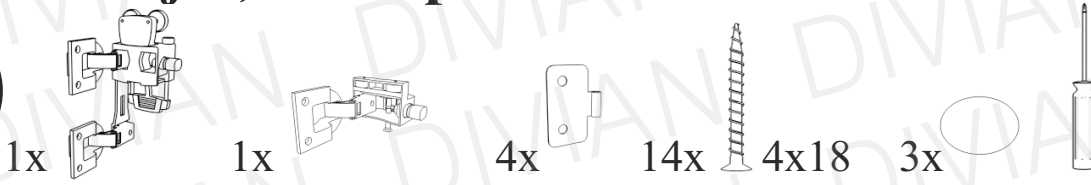

Jobbos ajtó, külső panel

14

4x

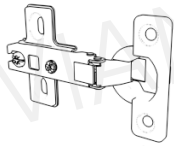

4x



1x



18x



4x18

2x

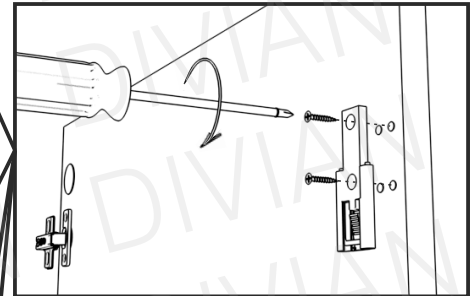
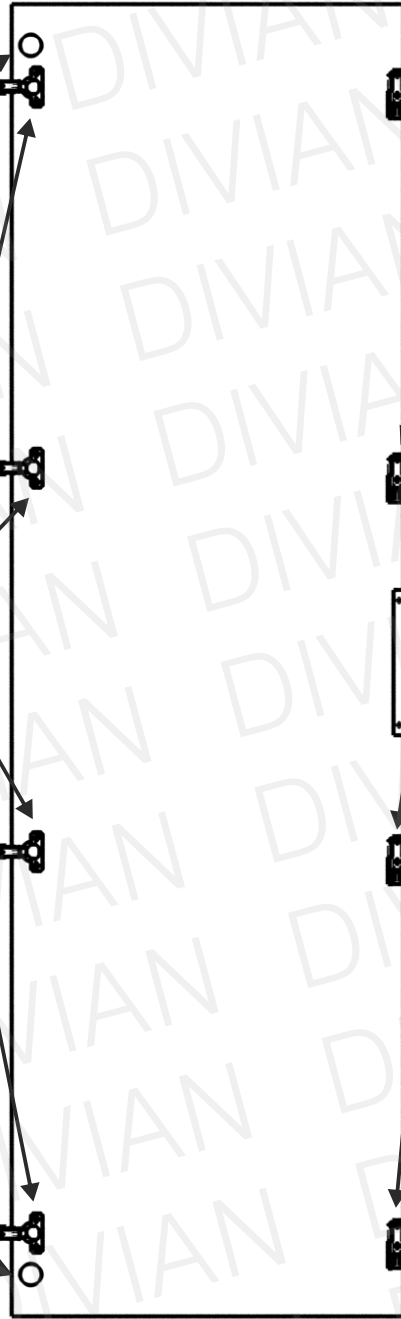
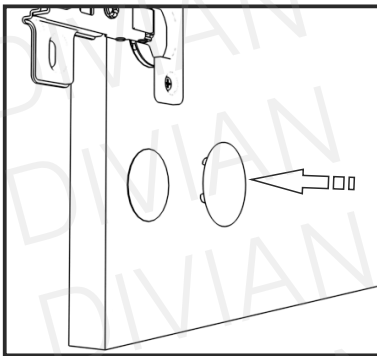
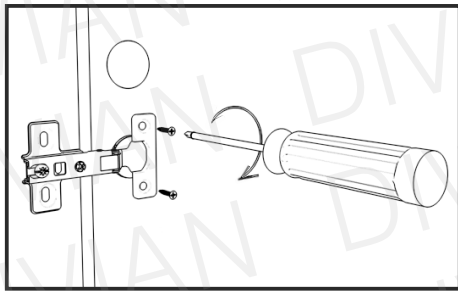
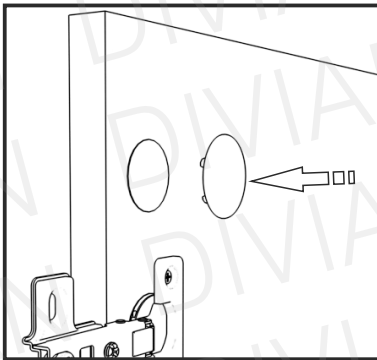

i A panel széléhez közelebbi, külső 2 furatba csavarja be az alkatrészt!

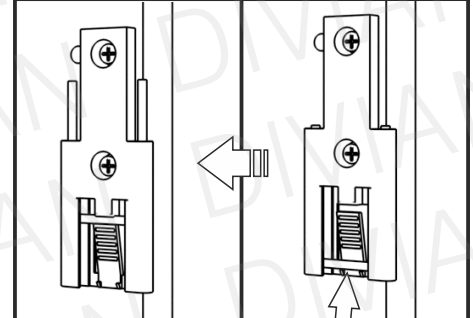

i Tolja fel az alkatrész U alakú fém részét!

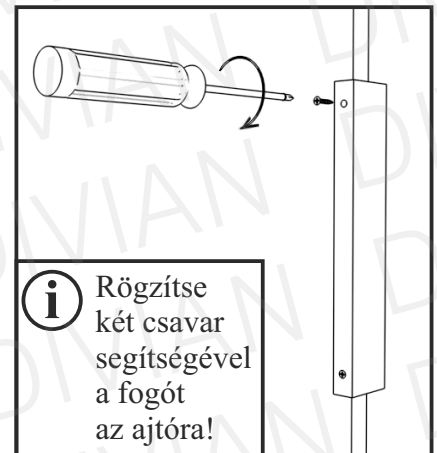

i Rögzítse két csavar segítségével a fogót az ajtóra!

15

8x 4x18

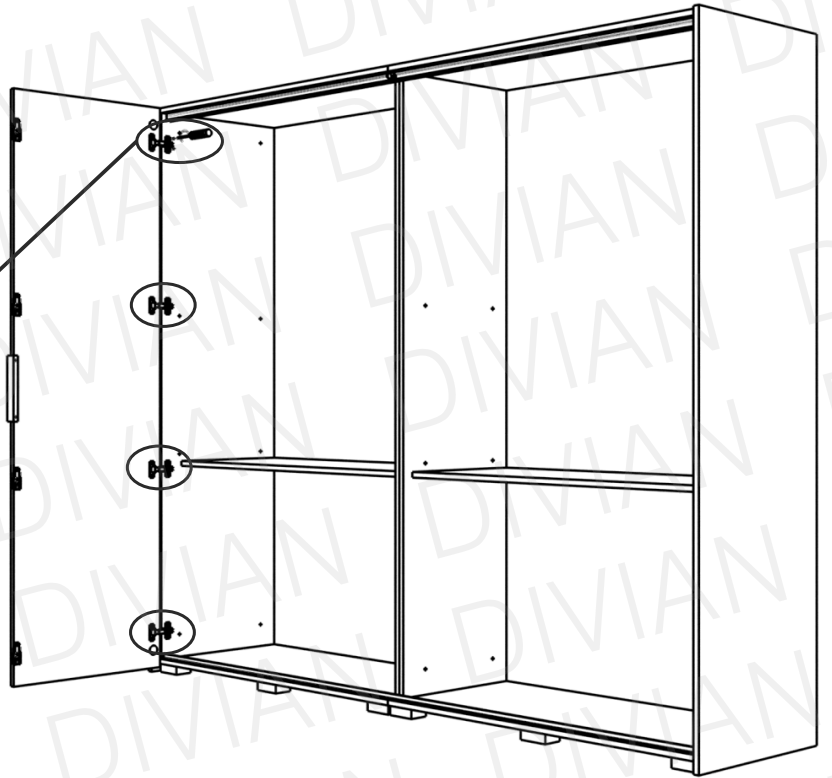
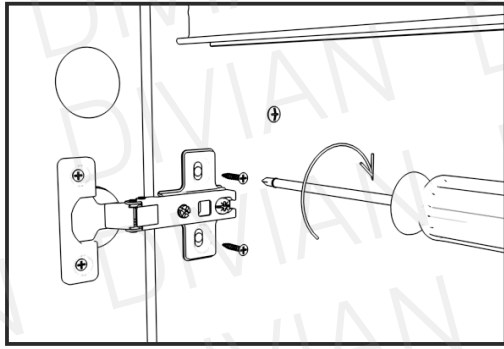
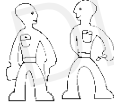
**i**

Az ajtók rögzítése után, amennyiben szükségesnek látják, a pántokon lévő két csavar segítségével állíthatják be az ajtók pontos helyzetét.

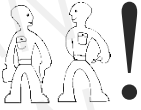
16**i**

A belső ajtó panelt óvatosan illesszék rá a külső ajtó panelre a 4 darab pánt segítségével. A két ajtó panel egymásra merőlegesen álljon, így könnyebben összeilleszthetőek.

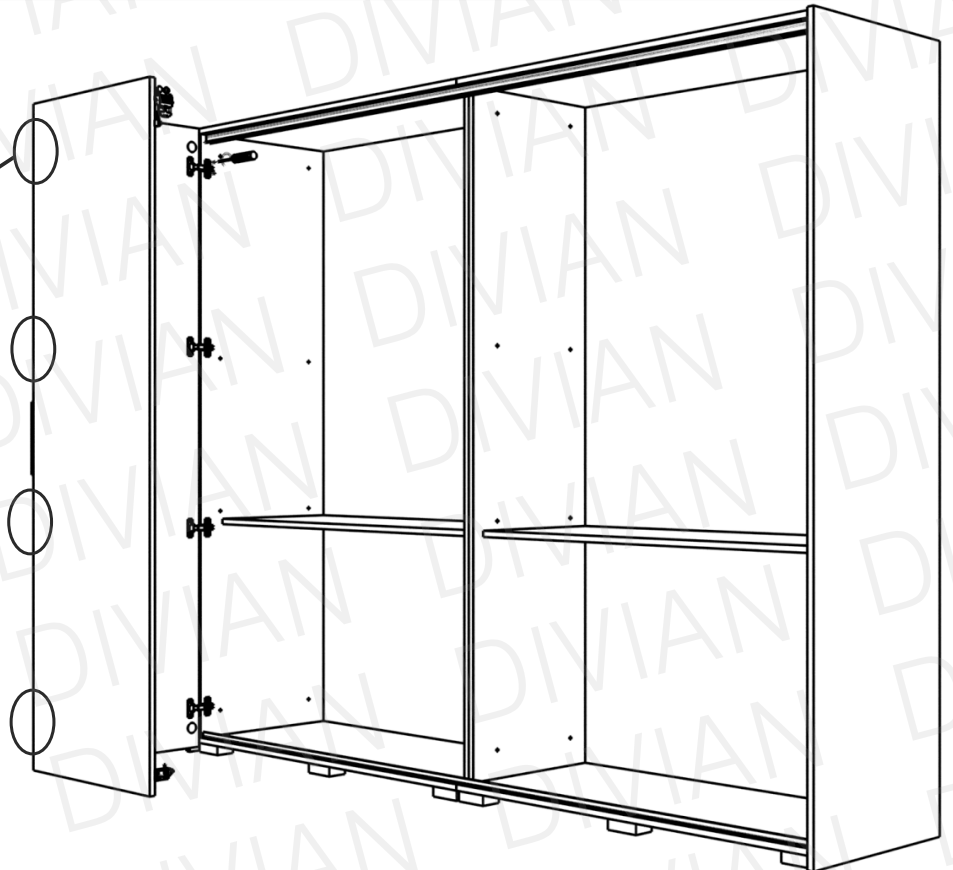
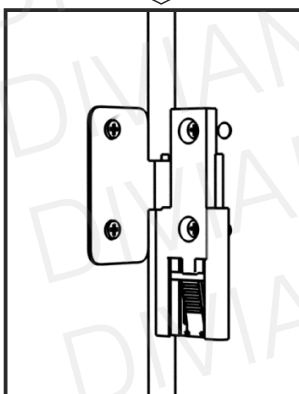
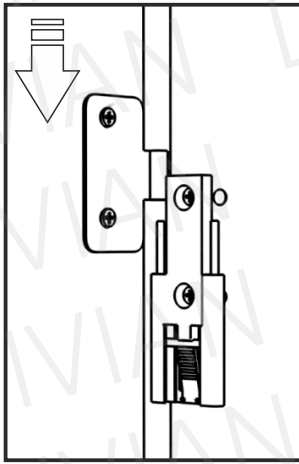

17

Hajtsák az ajtót a korpusz felé, a felső görgőt helyezték a felső sínre, majd tolják fel a belső görgőket is. Ezzel rázár a felső görgő a sínre.

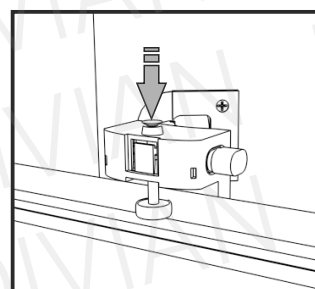
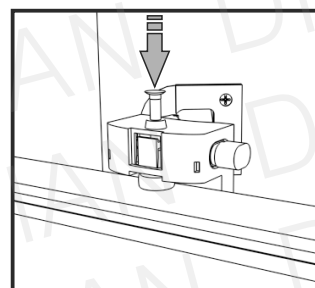
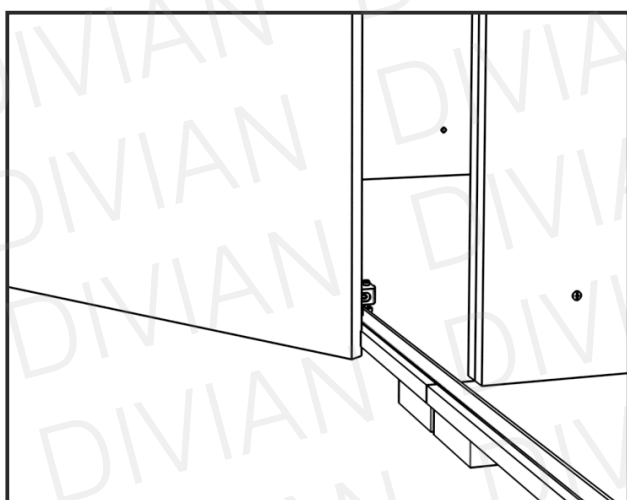
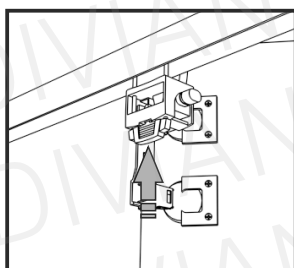
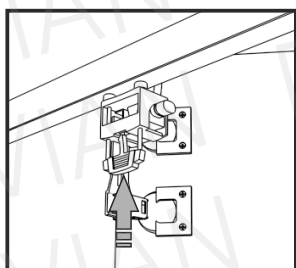
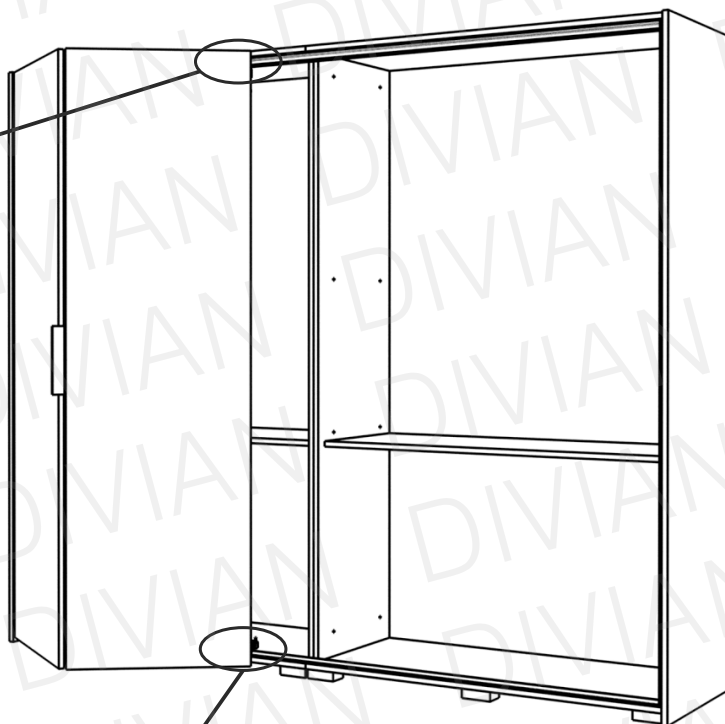
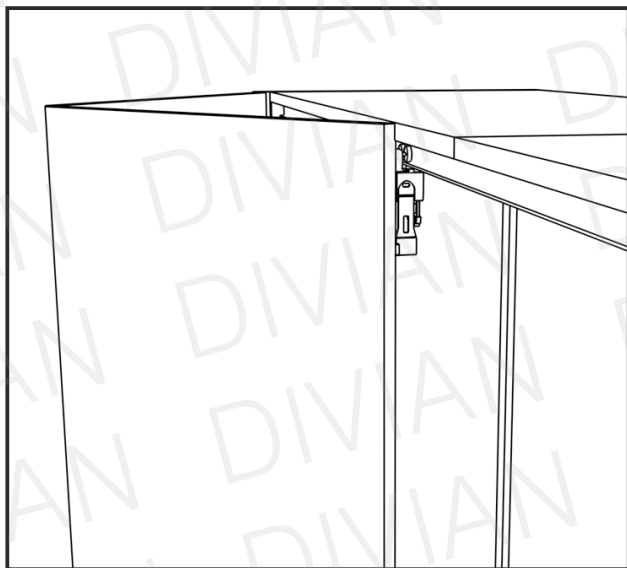

Az alsó görgőt helyezték az alsó sínre, majd nyomják le a kis fém rúd segítségével a belső görgőt. Ezzel rázár az alsó görgő a sínre.



Ismételjék meg a jobbos ajtó panelekkel is a 15., 16. és 17. lépést!

18

Ha szükségesnek látják az ajtók magasságát állíthatják a felső görgő alsó csavarjával.

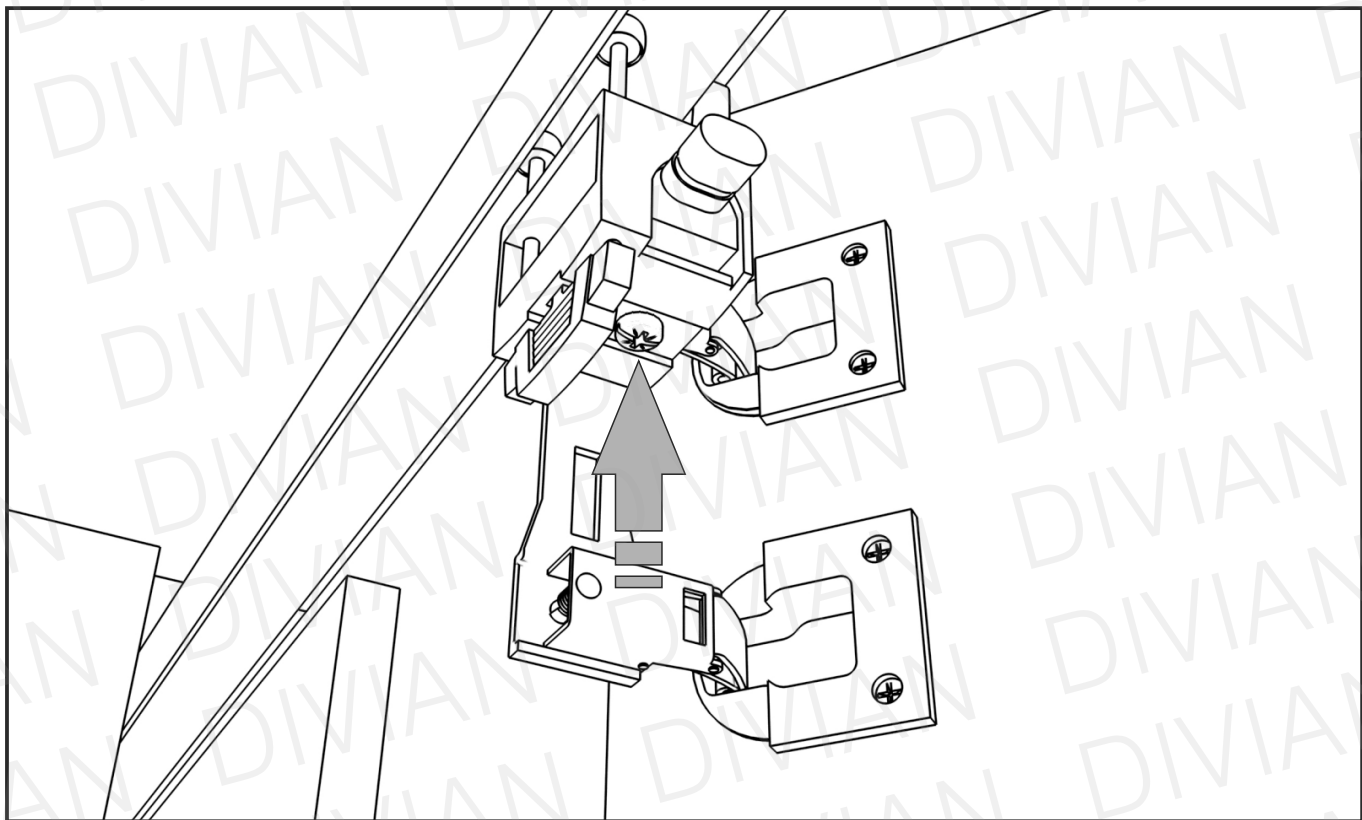
**19**

4x



8x

